



**SPECIFICATIONS
MODEL SC-600-SM**



COOKING CAPACITIES FOR THE SC-600

Pork Butt (7 lb.)	96 pieces	672 lb. total
St. Louis Ribs (2.75lb.)	112 pieces	308 lb. total
w/Optional Rib Racks	240 pieces	660 lb total
Chicken (3lb.)	200 pieces	600 lb. total
Brisket (12 lb.)	48 pieces	576 lb. total
Spare Ribs (3.5lb.)	48 pieces	168 lb. total

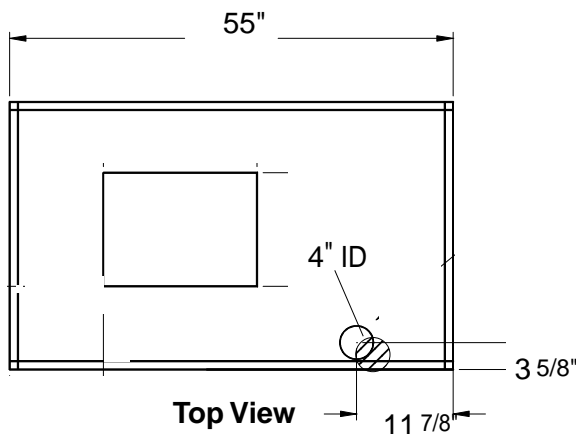
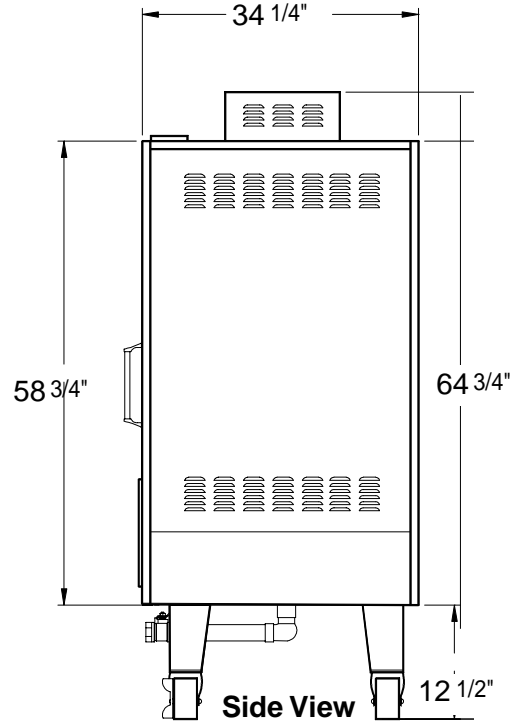
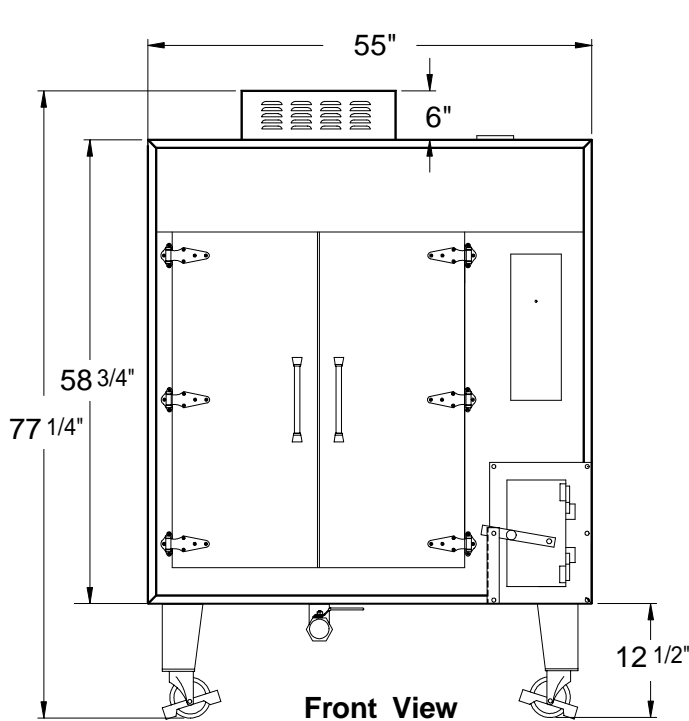

SC-600-SM

Electrical Requirements: 208 or 240 volts AC, 60 hertz, 1 phase, 45 amp wiring required.

Construction: All 18 gauge Stainless Steel.

Chipbox: Uses small logs, chunks or chips.

Dimensions: 72 1/4" tall, 55" wide, 34 1/4" deep

Shell Dimensions: 58 3/4" tall, 55" wide, 34 1/4" deep.

Food Racks: Eight food racks 33 1/2"x 31" 57.7 Sq.Ft. of Cooking Surface.

3" Spacing between food racks.

Air Circulation: Low Velocity Convection Fan.

Temperature Range: 100-325 degrees F.

Approvals: UL, ULC, NSF   

Venting: Must be installed under a vent hood.

Contact local code officials and a commercial kitchen ventilation contractor prior to installation.



Southern Pride Distributing, L.L.C.
2102 East Main Street - Marion, Illinois 62959
www.southern-pride.com sales@sopride.com service@sopride.com parts@sopride.com
Sales: 800-851-8180 Service: 800-437-2679

Phone: 618-997-9348
Fax: 618-993-5960
Service Fax: 618-993-0378